



Ohaus Corporation

29 Hanover Road

Florham Park NJ

07932-0900

DIAL-O-GRAM® BALANCE

Model 310

and

CENT-O-GRAM® BALANCE

Model 311

Instruction Manual

INTRODUCTION

This manual covers Installation and Operation for the Ohaus Dial-O-Gram® Balance Model 310 and Cent-O-Gram® Balance Model 311.

DESCRIPTION

Ohaus Dial-O-Gram® Balance Model 310 and Cent-O-Gram® Balance Model 311 are manufactured from high grade precision zinc castings for the base and precision aluminum castings for the beam. Agate bearings, hardened steel knife edges, and stainless steel pans ensure a high standard of quality for these products.

The 3-point base together with the special floating bearing principle and beam design eliminates the need to have a level adjustment. Zeroing is easily and quickly achieved by means of a counter balancing knob at the end of the beam. The balances are intended for use in education, and industry applications. They produce quick readings due to their damping mechanism. Both balances can also be used to make specific gravity measurements. Model 310 has two beams, each with a sliding poise, and a graduated dial and vernier which enables readings of 0.01 g. Capacity of the Model 310 is 310 grams. Model 311 has four beams, each with a sliding poise. Capacity of the Model 311 is 311 grams with a readability of 0.01 g.



Figure 1. Model 310.



Figure 2. Model 311.

UNPACKING AND ASSEMBLY INSTRUCTIONS

The balance has been shipped with each component packed securely in a protective,

expanded polystyrene container. Follow these instructions and you can assemble your balance in just a few minutes.

1. Remove the poly-container from the shipping carton and place it so that you can see the base and specific gravity stand. See Figure 3.
2. Cut the strap and lift off the upper half of the poly-container. Remove the base and specific gravity stand. Hold the base upside down. Insert the round, flat end of the stand through the slot in the base. Rotate stand into position as shown in Figure 4. It will turn easily if you rotate it as soon as the round end clears the opening. When the base and the specific gravity stand are upright, the OHAUS on the stand must be facing down.

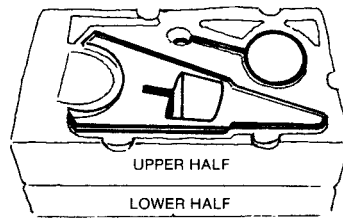

Figure 3.

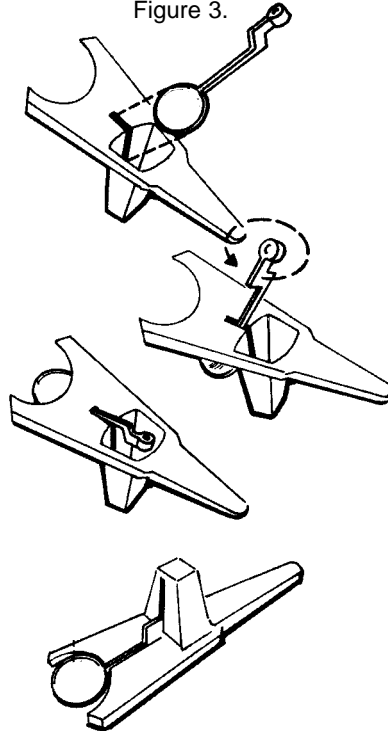

Figure 4.

UNPACKING AND ASSEMBLY INSTRUCTIONS (Cont.)

3. Remove the balance head from the lower half of the poly-container. Invert the balance head and nest it in the recess of the top half of the poly-container. See Figure 5.
4. Screw the threaded rod into the hole in the balance until it stops.
5. Slide the column down over the threaded rod. Hold the base and specific gravity stand in your left hand and slide them down over the threaded rod. (The column, base and balance head support bracket are keyed for correct assembly orientation.)
6. Slip the strap over the threaded rod into the recessed area of the base. Tighten the nut securely with the throw away wrench.
7. Turn the balance over. If the specific gravity stand is not already nested in the base, lift the round section, and it will slide down.
8. Place the pan on the pan support and insert the pan bow in the upper notch of the end loop as shown in Figure 6.

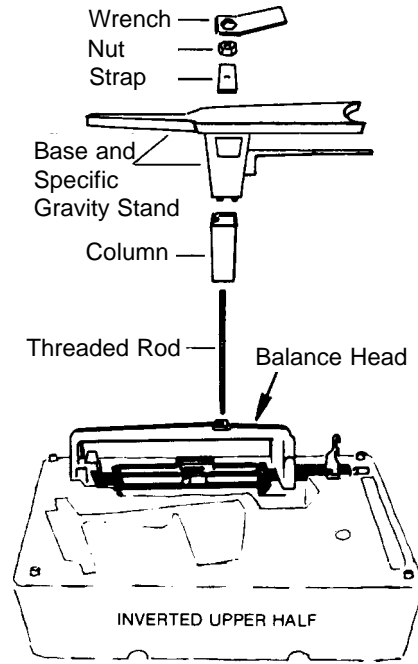

Figure 5.

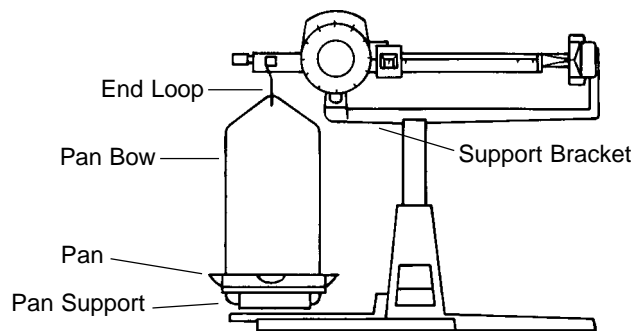

Figure 6.

ZEROING THE BALANCE

Slide all poises to their respective zero positions. Turn dial to zero position. You can now zero the balance by rotating the knurled balance compensator knob at the left end of the beam until the pointer on the right lines up with zero. (Note how quickly the magnetic damping brings the pointer to rest.)

Check the balance periodically since foreign material may accumulate on the beam or pan and cause a slight change in the zero balance position of the pointer. Whenever the balance is moved to a new location, the balance should be checked and zeroed again, if necessary.

WEIGHING

Weighing is a very simple and rapid operation. Place the specimen on the pan of the balance. Proceed as follows for the fastest method of weight determination.

Model 310

1. Move the 200 gram poise on the rear beam to the first notch which causes the pointer to drop, then move it back one notch, causing the pointer to rise.
2. Repeat this procedure with the 100 gram poise.
3. Turn the knob slowly until the pointer is exactly centered on the zero indicator.
4. The weight of the specimen is the sum of the values of both poise positions, the dial position and the vernier reading.

NOTE: With a little practice, you will become proficient in learning exactly how fast to turn the dial to come exactly to balance position the first time.

Shortcut procedures may be used in instances where approximate weight of the specimen is known, as follows:

For specimens less than 100 grams, omit step 1.

For specimens less than 10 grams, omit steps 1 and 2.

Figure 7. Example of 146.74 Gram Reading.

READING THE VERNIER - Model 310

Each graduation on the dial has a value of 0.1 gram. A vernier adjacent to the dial breaks down these values in 0.01 gram increments. To read the vernier, read the nearest gram value to the right of the zero vernier graduation. Add to that the vernier graduation value at the vernier line which most closely lines up with any of the other dial graduations. Figure 8 indicates a reading of 6.74 grams.

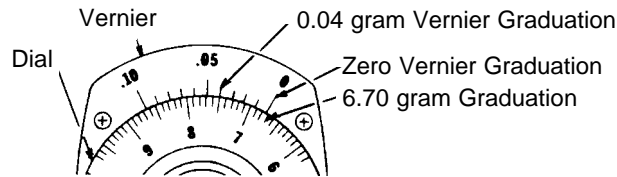

Figure 8. Vernier Dial Reading of 6.74 Grams.

Model 311

1. Working from the rear beam forward, move the 200 gram poise on the rear beam to the first notch which causes the pointer to drop, then move it back one notch, causing the pointer to rise
2. Repeat this procedure with the 100 gram poise.
3. Repeat this procedure with the 10 gram poise.
4. Slide the 1 gram poise to the position which brings the pointer to zero. The weight of the specimen is the sum of values of all poise positions, read directly from the graduated beams. See Figure 9.

NOTE: With a little practice, you will become proficient in learning exactly how fast to turn the dial to come exactly to balance position the first time.

Shortcut procedures may be used in instances where approximate weight of the specimen is known, as follows:

- For specimens less than 100 grams, omit step 1.
- For specimens less than 10 grams, omit steps 1 and 2.
- For specimens less than 1 gram, omit steps 1, 2 and 3.

Figure 9. Example of 183.6 Gram Reading

Specific Gravity determinations are easily made on the balance. Swing the pan support and pan out of the way. Raise the specific gravity platform to the desired position by grasping the round end. Release platform at desired elevation and it will lock in that position.

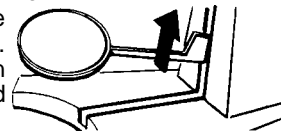

Figure 10.

SPECIFIC GRAVITY DETERMINATIONS (Cont.)

The specimen can then be suspended from a fine wire or thread from the lower hook of the end loop into a beaker or other suitable container of water or other liquid. If a great number of determinations are to be made on small solids, the use of a Model # 113 gem Holder, Counter Weight and Beaker is recommended. This provides a rapid method of weighing the object under water and eliminates the cumbersome task of tying a string or piece of fine metal to the object.

SOLIDS - (denser than water)

To determine specific gravity of solids denser than water, the specimen should be first weighed in air and then weighed immersed in water.

$$S. G. = \frac{\text{Weight in air}}{\text{Weight in air minus weight in water}}$$

SOLIDS - (less dense than water)

To determine the specific gravity of solids less dense than water, it is necessary to attach a sinker and then make the following weighings:

- a. Weight of body in air.
- b. Combined weight of body in air plus sinker in water .
- c. Weight of both body and sinker in water.

$$\text{Specific Gravity} = \frac{a}{b-c}$$

CARE AND MAINTENANCE

With reasonable care, your Balance can be kept in good working order. Keep it clean and do not drop it. Foreign matter can be most easily removed with an air syringe. When the balance is not used, it should be protected by a balance cover. (Part No. 110). Never apply oil or any lubricant to the knife edges or bearings; this will lower the accuracy of the balance. From time to time, it may be necessary to clean the damping magnet faces. This is best done by inserting a piece of adhesive-backed tape into the damper vane slot (right side of beam), and pressing it against the magnet face. The tape will pick up foreign material and prevent it from interfering with movement of the damper vane.

OPTIONAL ACCESSORIES

<u>DESCRIPTION</u>	<u>PART NO</u>
Balance Cover	110-00
Gem Holder Kit	113-00
Test Tube Kit	76912-01

SERVICE INFORMATION

For Service assistance in the United States, please call Ohaus Corporation toll-free at (800) 526-0659. An Ohaus Product Service Specialist will be available to help you.



LIMITED WARRANTY

Ohaus products are warranted against defects in materials and workmanship from the date of delivery through the duration of the warranty period. During the warranty period Ohaus will repair, or, at its option, replace any component(s) that proves to be defective at no charge, provided that the product is returned, freight prepaid, to Ohaus.

This warranty does not apply if the product has been damaged by accident or misuse, exposed to radioactive or corrosive materials, has foreign material penetrating to the inside of the product, or as a result of service or modification by other than Ohaus. In lieu of a properly returned warranty registration card, the warranty period shall begin on the date of shipment to the authorized dealer. No other express or implied warranty is given by Ohaus Corporation. Ohaus Corporation shall not be liable for any consequential damages.

As warranty legislation differs from state to state and country to country, please contact Ohaus or your local Ohaus dealer for further details.

Ohaus Corporation
29 Hanover Road,
Florham Park, NJ 07932, USA
Tel: (973) 377-9000,
Fax: (973) 593-0359

With offices worldwide.