

seca

seca 725

Congratulations

In purchasing the **seca 725** baby scale, you have acquired a highly-accurate and yet sturdy piece of equipment.

seca has been putting its experience at the service of health for over 50 years, and as market leader in many countries of the world, is always setting new standards with its innovative weighing and measuring developments.

The **seca 725** mechanical baby scale is designed for use in hospitals and paediatric practices.

The scale consists of a metal housing and tray with a white finish.

These are easy to clean and ensure that the baby can be weighed safely on the scale.

The **seca 725** also has an easy-to-read sliding weight bar with 5 g / 1/4 oz graduations.

Safety

Before using the new scale, please take a little time to read the following safety instructions.

- Follow the instructions for use.
- Never leave an infant on the scale unsupervised.
- Ensure that the tray is cleaned and disinfected regularly to avoid infectious diseases being passed on.
- Do not drop the scale or subject it to violent shocks.
- Have repairs carried out solely by authorised persons.

Set up and align scale

1. Remove packaging

Open the cardboard box and remove the tray and scale.

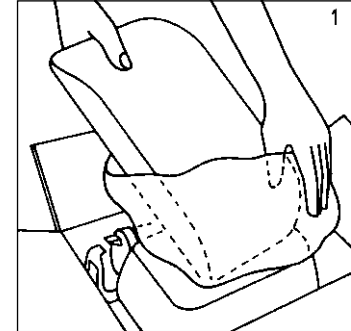

2. Remove transport securing device

Remove the O-ring which secures the sliding weights.

Retain this for further transport operations.

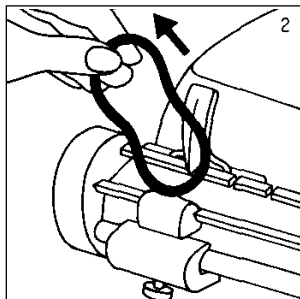

3. Secure sliding weight bar

Secure the sliding weight bar by tilting the locking device downwards.

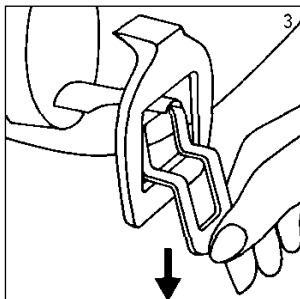

4. Place tray on scale

Place the tray centrally on the scale.

The locking levers must engage under the housing.

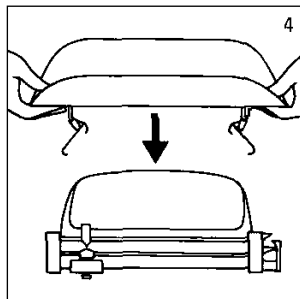

5. Attach tray

Attach the tray to the scale by pressing down the locking levers.

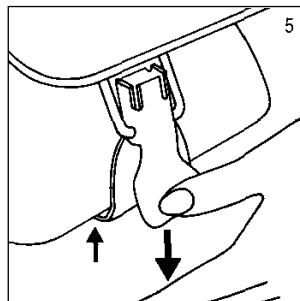

6. Release lock

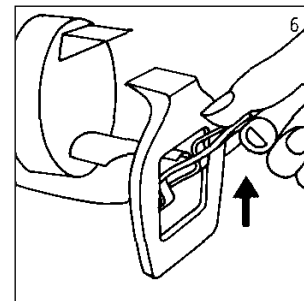

7. Approximate taring

For the scale to display the correct weight, it must first be set to 0 kg/lbs.

To do so, push both sliding weights on the sliding weight bar to 0. If the hand and counter-hand do not line up, the 0 value must be set using the tare weight. To do so, undo the knurled nut (see Fig. 8) and push the tare weight onto the rod until the hand and counter-hand line up.

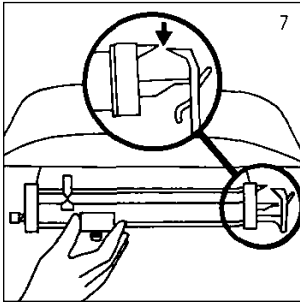

8. Fixing the tare weight in position

Fix the tare weight in position using the knurled nut. Objects on the tray such as pads etc. weighing up to 3000 g / 6.6 lbs can be tared using the tare weight.

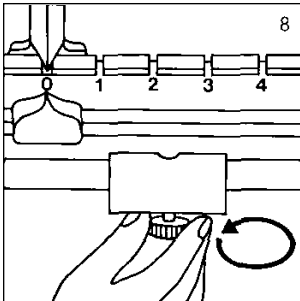

9. Fine adjustment

The hand and counter-hand can be set exactly by turning the fine taring screw. To do so, the fine taring screw is turned to the right or left until the hand and counter-hand line up exactly.

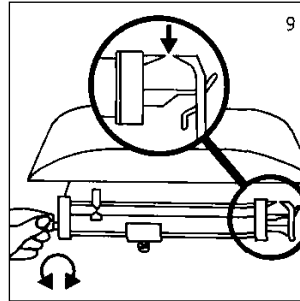

Operation

Once the scale has been prepared as described in the section entitled "Set up and align scale", you can start weighing. Place the infant in the tray and first slide the large sliding weight to approximately the right weight.

Now use the small sliding weight to determine the exact weight. To do so, slide the small sliding weight along until hand and counter-hand line up.

Read the weight value off the scale on the sliding weight bar.

Cleaning

Clean the housing and the tray as required using a domestic cleaning agent or commercially-available disinfectant. Follow the manufacturer's instructions.

What do I do if...

- ... no weight is displayed when a load is placed on the scale?
- transport locking lever (see Fig.) has not been released
- transport securing device, i.e. the O-ring, has not been removed.

Technical data

Capacity:	16 kg / 32 lbs
Graduations:	5 g / 1/4 oz
Dimensions (WxHxD):	550 mm / 2 3/4 inch 190 mm / 7 1/2 inch 305 mm / 12 inch
Weight:	approx. 6 kg / 14 lbs
Temperature range:	+10 °C to +40 °C
Accuracy:	± 0,25 %

Disposal

If the scale can no longer be used, the responsible waste disposal association will be glad to provide information about the measures necessary to dispose of it properly.

Warranty

A two-year warranty from date of delivery applies to defects attributable to poor materials or workmanship. All moveable parts – batteries, cables, mains units, rechargeable batteries etc. – are excluded. Defects which come under warranty will be made good for the customer at no charge on production of the receipt. No further claims can be entertained. The costs of transport in both directions will be borne by the customer should the equipment be located anywhere other than the customer's premises. In the event of transport damage, claims under warranty can be honoured only if the complete original packaging was used for any transport and the scale secured and attached in that packaging just as it was when originally packed. All the packaging should therefore be retained.

A claim under warranty will not be honoured if the equipment is opened by persons not expressly authorised by seca to do so.

We would ask our customers abroad to contact their local sales agent in the event of a warranty matter.

seca gmbh & co. kg.
Medizinische Waagen und Messsysteme
Hammer Steindamm 9-25
22089 Hamburg
Germany
Telephone +49 40 20 00 00 0
Telefax +49 40 20 00 00 50
E-Mail info@seca.com

seca branches around the world:

seca austria
seca france
seca mexico
seca nihon
seca north america east
seca north america west
seca schweiz
seca united kingdom
seca zhong guo

All contact data under www.seca.com