

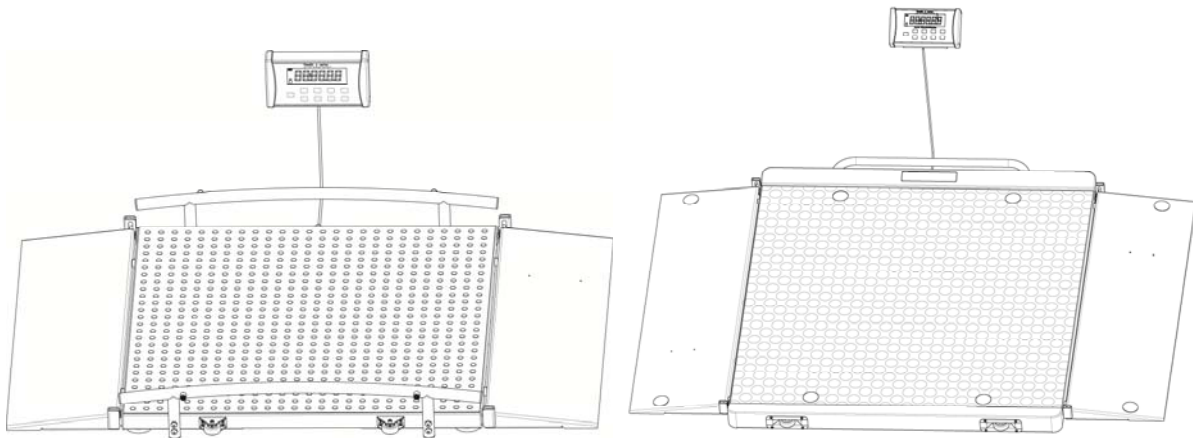

Model 2650KL / 2700KL Patient Wheelchair Scales



User Instructions

Thank you for your purchase of this Health o meter® Professional product. Please read this manual carefully, and keep it for easy reference or training.

TABLE OF CONTENTS

Caution and Warning.....	3
Specifications for These Scales	4
Certifications / Connectivity / Disposal	6
Assembly Instructions 2650KL Scale	7
Assembly Instructions 2700KL Scale	11
Display Assembly Wall Mounting Instructions	15
Setup / Batteries / Transport	16
Quick Start Instructions	18
Maintenance.....	22
Calibration	23
Troubleshooting	24
Warranty.....	25

Note: These scales have been factory calibrated, and does not require calibration prior to use.

Please register your scale for warranty coverage at:

<http://www.homscales.com/customer/registration.aspx>

For User Instructions updates and revisions, please go to:

<http://www.homscales.com>

CAUTION AND WARNING

- To prevent injury and damage to your scale, please follow these instructions very carefully.
- Assemble and operate the scale per the enclosed user instructions.
- Operate these scales exclusively with the AC adapter provided by Health o meter. Use of an unspecified adapter will void the warranty, and can pose a serious safety hazard.
- Prior to using these scales, inspect the AC adapter cord for cracking/fraying, or for broken/bent plug prongs.
- Prior to using these scales, ensure that the AC adapter is plugged into an outlet with the rated voltage appropriate for operation.
- Ensure that the AC adapter outlet is wired to a circuit breaker or other protected power source.
- Unplug the AC adapter, and carefully store both the adapter and adapter cord before moving the scale.
- Ensure that the AC adapter and scale do not come in contact with liquids, excessive temperature, or excessive humidity.
- Operating these scales at voltages and frequencies other than specified can damage the equipment and will void the warranty.
- Do not transport the scale with any weight on the platform.
- Do not exceed recommended weight limit of 1000 lb / 454 kg for these scales.
- For accurate weighing, these scales must be placed on a flat, stable surface. Also verify before each use the proper operation according to the procedure described in this manual.
- Do not use in the presence of flammable or explosive materials.
- For accurate weighing, if the “Lo bAtt” indicator activates, replace the batteries or switch to the AC adapter as soon as possible.
- When operating the scale with the display assembly on a flat surface, ensure that the load cell cable is routed to prevent a tripping hazard to the patient or user.
- When operating the scale with the display assembly on the wall, ensure that the display is securely mounted with the appropriate anchors and screws.
- To prevent scale damage, ensure that the wall-mounted display is removed off the wall prior to scale transport.
- When wall mounting the display assembly, ensure that the mounting location is free of electrical lines, gas pipes, and other safety hazards.
- When replacing / inserting batteries, be sure to use all new batteries.

CAUTION AND WARNING

- To prevent patient injury, the patient must be attended throughout the entire weighing event. Exercise caution when rolling patient onto and off of the scale.
- To prevent injury, exercise care when adjusting wheelchair ramps.
- To prevent injury and damage to your scale, do not drop or mishandle scale, while handling or transporting scale. As this can permanently damage the load cells and may also cause injury to one self.

SPECIFICATIONS FOR THESE SCALES

General

The Model 2650KL and 2700KL Patient Scales use highly sophisticated microprocessor technology. Each precision scale is designed to provide accurate, reliable, and repeatable weight measurements. In addition, each scale is designed to provide the user with features that make the weighing process simple, fast, and convenient.

These scales are set up to use motion-sensing weighing technology in order to determine the actual weight of a moving patient.



Weight can be displayed in pounds or in kilograms. For privacy and convenience in use, the scale features a remote display head which may be held by the operator, placed on a table or other flat surface, or mounted on a wall. Both scale models have 2 wheels built-in for easy mobility. **Each scale can be powered using an AC adapter (included), or by 6 - AA batteries (not included).**

2650KL / 2700KL Specifications

Capacity and Resolution	2650KL / 2700KL: 1000 lb x 0.2 lb (454 kg x 0.1 kg)	
Power Requirements	120V - 240V AC, 50 - 60Hz-9V DC adapter or 6 - AA batteries	
Environmental	Operating temperatures: 50°F to 95°F (10°C to 35°C) Storage temperatures: 30°F to 125°F (0°C to 50°C) Maximum Humidity: 85% RH	
Physical Dimensions	Platform-2650KL Length: 31-½" (80.0 cm) Width: 31-¼" (79.4 cm) Height: 2-½" (6.2 cm)	Assembled Size and Weight Length: 34-¼" (87 cm) Width: 33" (83.8 cm) Height: 6" (15.2 cm) Weight: 80.5 lb (36.5 kg)
Physical Dimensions	Platform-2700KL Length: 32-½" (82.6 cm) Width: 36" (91.4 cm) Height: 2-½" (6.2 cm)	Assembled Size and Weight Length: 41-½" (105.4 cm) Width: 56-¼" (143 cm) Height: 3-⅛" (8 cm) Weight: 80.5 lb (36.5 kg)

CERTIFICATIONS / CONNECTIVITY / DISPOSAL

Certification Descriptions

	Pelstar, LLC has been officially certified as the manufacturer of Health o meter® Professional medical devices. The Pelstar, LLC quality assurance system covers the development, production, sales and service of medical scales and measuring systems.
	This product is tested to and meets the requirements of: 1. UL60601-1 First Edition: Safety for Medical Electrical Equipment 2. CSA C22.2 No. 601-1 M90: Medical Electrical Equipment

2650KL / 2700KL Scale Connectivity Information

To enable reliable transmission of weight, height, and Body Mass Index (BMI) data, these scales are designed to connect to a computer, monitor, or other electronic device via a built-in USB port. This connectivity helps minimize a source of potential medical errors caused by incorrectly copying and then recording patient data.

These scales are EMR-EHR compatible. For more information regarding how to connect these scales to other electronic devices, please contact Health o meter® Professional Scales Technical Support, available during normal business hours at 1-800-683-3722

2650KL / 2700KL Scale Disposal



These Health o meter® Professional scales must be disposed of properly as electronic waste. Follow the national, regional or local regulations which apply to you for disposal of electronic waste or batteries. Do not dispose of this device in the domestic waste stream.

2650KL ASSEMBLY INSTRUCTIONS

Before Assembly

Each 2650KL scale is shipped disassembled in a single carton. Carefully inspect the carton for shipping damage before unpacking. If damage is found, contact your shipper or a Health o meter® Professional representative immediately at 1-800-815-6615. Claims must be filed with the shipper as soon as possible after receipt of the package. The following information details what you will find inside the main carton as you unpack the parts for assembly.

To prevent scratching any components, carefully remove each assembly from the carton and unwrap the packing materials. Set the carton aside for storage. To avoid damaging the scale parts when unpacking, do not use a box cutter, knife, scissors, or any sharp object to open the protective inner packaging.

Parts List

- (1) Scale Platform
- (1) User Instructions
- (1) Box Containing:
 - (1) Display Assembly
 - (1) Load Cell Connector Cable
 - (1) AC Adapter
 - (4) Feet

Note: In order to mount the scale's display assembly onto the wall, a set of wall anchors and screws will be required (not included). Refer to the user instructions for secure display assembly mounting.

Tools Required

Phillips head screwdriver (not included), Allen wrenches (included).

2650KL ASSEMBLY INSTRUCTIONS (CONTINUED)

Assembling the 2650KL Scale (Refer to Figures 1-3)

Caution: It is recommended that the assembly be performed by two persons.

1. Place scale platform on a flat, level, and dry surface, and carefully turn the platform upside down.

Caution: Ensure that the wheelchair ramps are held in place when moving the scale - ramps can flip open.

2. Thread the (4) feet into the underside of the platform. Each foot should be completely hand tightened into the platform. Back feet out 1-½ full turns. This will allow for proper load cell operation and scale accuracy.

3. Carefully flip the scale over to its upright position on the floor.

Warning: Do not drop scale, as this can permanently damage the load cells.

4. Adjust the feet to level the scale. Be certain that the feet are not completely tightened into the platform for proper load cell operation.

5. Open the scale to its operational position by folding open the wheelchair ramps.

6. Connect the load cell cable to the scale platform by inserting the load cell cable connector into the load cell port (see Figure 2).

7. Ensure that the other load cell cable connector is securely plugged into the display assembly load cell jack (located on the rear panel of the display assembly). The load cell jack is labeled "LOAD CELL" (see Figure 3).

8. If the AC adapter will be used, connect the AC adapter cord plug into the AC power jack, located on the back of the display assembly. The AC power jack is labeled "POWER" (see Figure 3).

9. Connect the AC adapter to the power port, located on the back of the display assembly.

Caution: Do not plug the scale into a power source until the scale is fully assembled.

10. The scale is now assembled. Plug the AC adapter into a power source and / or insert the batteries.

11. Carefully position the display assembly on the desk, table, or other flat surface.

Caution: Ensure that the load cell cable is adequately secured to prevent a tripping hazard to the patient or user.

Note: Refer to "Display Assembly Wall Mounting Instructions", located in this User Instruction Manual.

2650KL ASSEMBLY INSTRUCTIONS (CONTINUED)

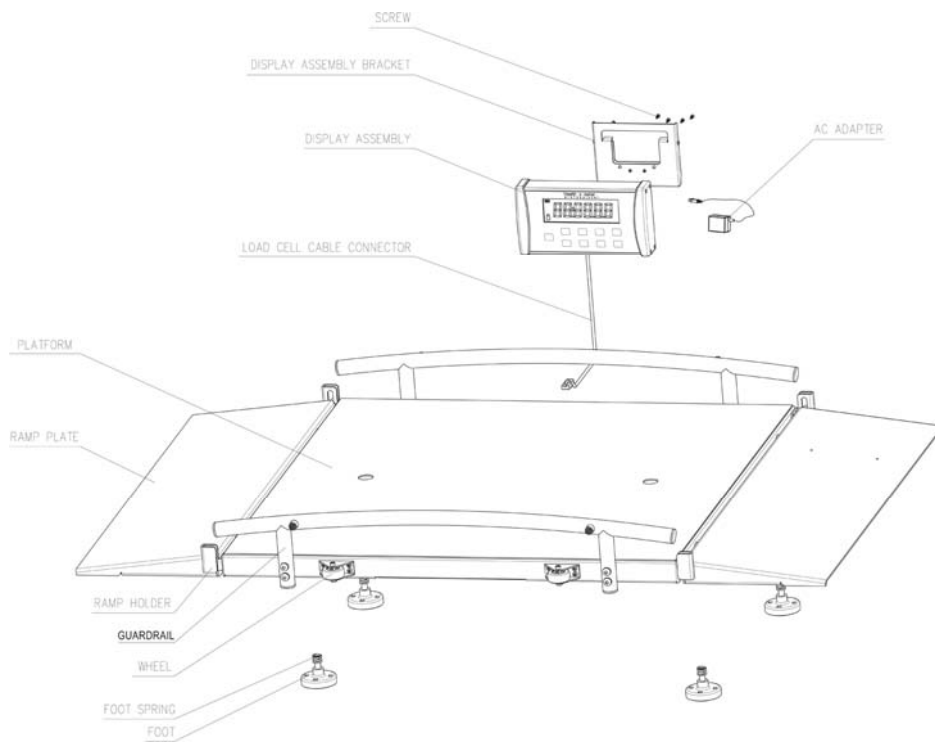

Figure 1

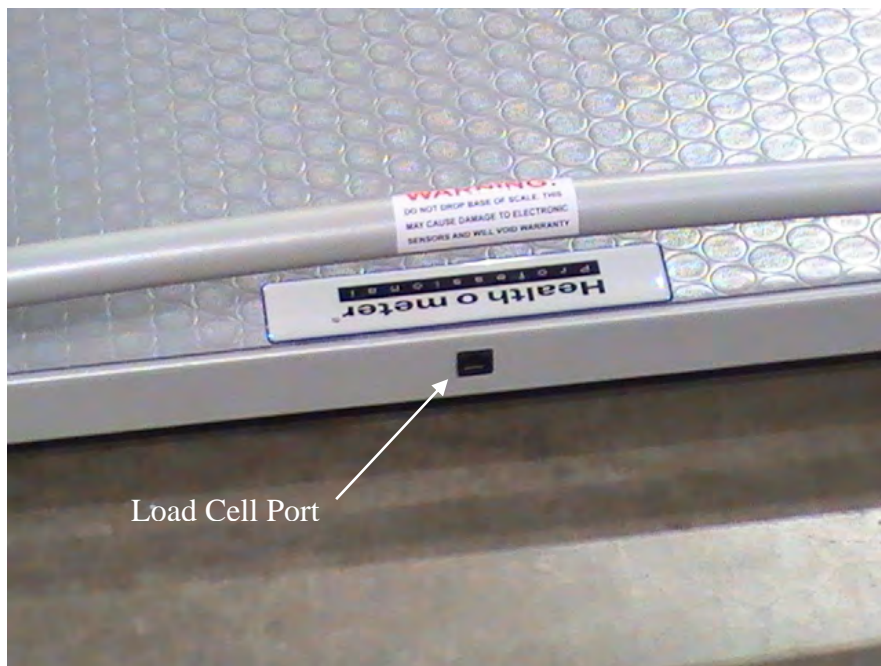

Figure 2

2650KL ASSEMBLY INSTRUCTIONS (CONTINUED)



Figure 3

2700KL ASSEMBLY INSTRUCTIONS

Each 2700KL scale is shipped disassembled in a single carton. Carefully inspect the carton for shipping damage before unpacking. If damage is found, contact your shipper or a Health o meter® Professional representative immediately at 1-800-815-6615. Claims must be filed with the shipper as soon as possible after receipt of the package. The following information details what you will find inside the main carton as you unpack the parts for assembly.

To prevent scratching any components, carefully remove each assembly from the carton and unwrap the packing materials. Set the carton aside for storage. To avoid damaging the scale parts when unpacking, do not use a box cutter, knife, scissors, or any sharp object to open the protective inner packaging.

Parts List

- (1) Scale Platform
- (1) User Instructions
- (1) Box Containing:
 - (1) Display Assembly
 - (1) Load Cell Connector Cable
 - (1) AC Adapter
 - (4) Feet

Note: In order to mount the scale's display assembly onto the wall, a set of wall anchors and screws will be required (not included). Refer to the User Instructions for secure display assembly mounting.

Tools Required

Phillips head screwdriver (not included), Allen wrenches (included).

2700KL ASSEMBLY INSTRUCTIONS (CONTINUED)

Assembling the 2700KL Scale (Refer to Figures 4-6)

Caution: It is recommended that the assembly be performed by two persons.

1. Place scale platform on a flat, level, and dry surface, and carefully turn the platform upside down.

Caution: Ensure that the wheelchair ramps are held in place when moving the scale - ramps can flip open.

2. Thread the (4) feet into the underside of the platform. Each foot should be completely hand tightened into the platform. Back out 1-½ full turns. This will allow for proper load cell operation and scale accuracy.

3. Carefully flip the scale over to its upright position on the floor.

Warning: Do not drop scale, as this can permanently damage the load cells.

4. Adjust the feet in order to level the scale. Ensure that the feet are not completely tightened into the platform for proper load cell operation.

5. Open the scale to its operational position by folding open the wheelchair ramps.

6. Connect the load cell cable to the scale platform by inserting the load cell cable connector into the load cell port (See Figure 5).

7. Ensure that the other load cell cable connector is securely plugged into the display assembly load cell jack (located on the rear panel of the display assembly). The load cell jack is labeled "LOAD CELL" (see Figure 3).

8. If the AC adapter will be used, connect the AC adapter cord plug into the AC power jack, located on the back of the display assembly. The AC power jack is labeled "POWER" (see Figure 3).

Caution: Do not plug the scale into a power source until the scale is fully assembled.

9. The scale is now assembled. Plug the AC adapter into a power source and / or insert the batteries.

10. Carefully position the display assembly on the desk, table, or other flat surface.

Caution: Ensure that the load cell cable is adequately secured to prevent a tripping hazard to the patient or user.

Note: Refer to "Display Assembly Wall Mounting Instructions", located in this user instruction Manual.

2700KL ASSEMBLY INSTRUCTIONS (CONTINUED)

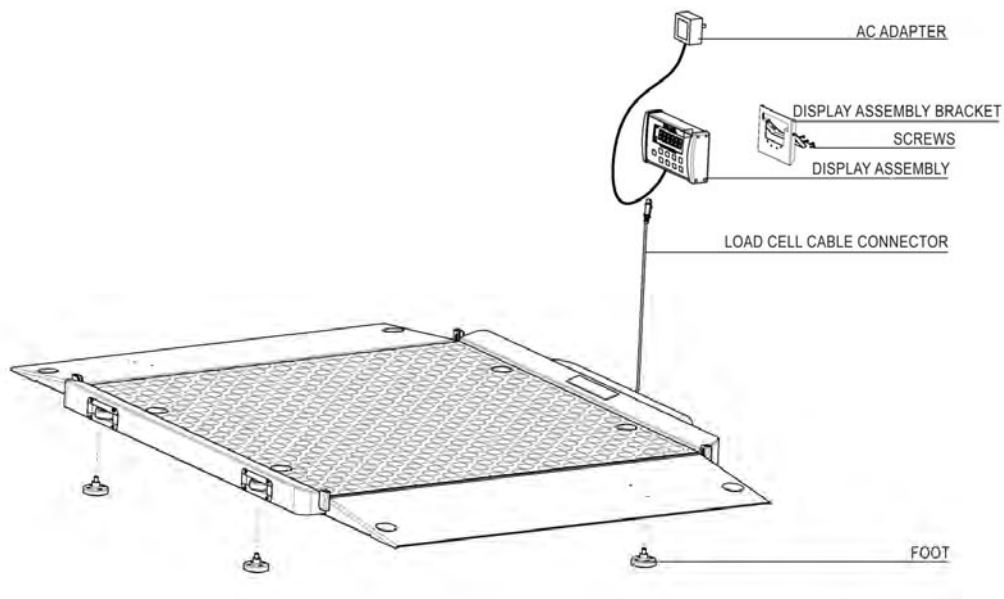

Figure 4



Figure 5

2700KL ASSEMBLY INSTRUCTIONS (CONTINUED)



Figure 6

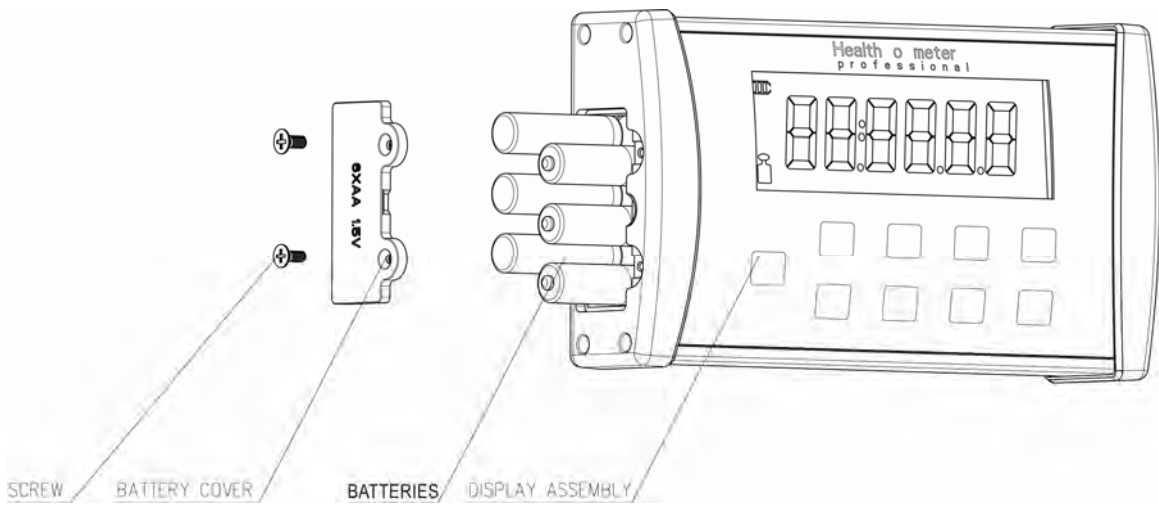

Figure 7

DISPLAY ASSEMBLY WALL MOUNT INSTRUCTIONS

Display Assembly Wall Mounting Instructions

Caution: When wall mounting the display assembly, ensure that the mounting location is free of electrical lines, gas pipes, and other safety hazards. Ensure that wall is of construction that can support the display assembly.

1. Position the display assembly on the wall, and carefully trace around the display outline.
2. Mark a level horizontal line, 2- $\frac{3}{4}$ " (70mm) below the top of the display outline.
3. Mark a vertical line through the center of the display outline. The center line is 4- $\frac{1}{2}$ " (114mm) from each side of the display outline.
4. On the level horizontal line, mark two drill holes 2- $\frac{1}{4}$ " (57mm) away from the center line.
5. Use the appropriate plastic or metal anchors for the type of wall construction, and carefully drill the appropriate sized holes.
6. Insert the anchors into the wall, and screw in the two mounting screws into the anchors. Adjust the screw head depth such that the bracket can be mounted over the two screw heads.
7. Position the display assembly mounting holes onto the mounting screws, and pull down on the display assembly to secure the bracket over the screws.

Required Parts

- (1) Display Assembly
- (2) #8 Anchoring Screws (4.2mm nominal OD)
- (2) Mounting Anchors, Compatible with Wall Construction

Note: Anchors and Anchoring Screws are not included with these scales.

SETUP / BATTERIES / TRANSPORT

Preparing the 2650KL / 2700KL Scale for Use

1. Remove the protective plastic film covering the display (the film says "FACTORY CALIBRATED").
2. Place batteries into the battery holder (see Figure 7).
3. Plug the scale's AC adapter into the power source.
4. Ensure all objects are removed from the scale's platform. Press the **ON/OFF** button to turn the scale on. The display will show "Start", then "0.0LB" or "0.0KG".
5. Press the **UNIT** button to select the weight mode (lb or kg).

Note: These scales will always default to the settings and units last used (lb or kg).

6. When the AC adapter is disconnected from the scale, the scale will switch to battery power if batteries are installed.

Note: If the set up procedure failed, refer to the troubleshooting instructions. If the problem is not corrected, refer to qualified service personnel.

Replacing / Inserting Batteries

1. Unplug the AC adapter from the power source.
2. Remove the battery cover on the side of the display assembly by unscrewing the (2) battery cover screws (see Figure 7).
3. Replace or install the batteries with new units. Health o meter recommends using an alkaline or lithium battery, rated for 130°F (54°C) operation. Do not use Zinc-Carbon batteries.
4. Re-attach the battery cover to the display assembly.

Warning: If the scale will not be used for some time, remove the batteries to avoid a safety hazard. Disposal of batteries must be performed in accordance with the prevailing national, regional or local regulations which apply to you.

SETUP / BATTERIES / TRANSPORT (CONTINUED)

Preparing a 2650KL / 2700KL Scale for Transport

The ramps on these scales can be easily folded for movement from one room to another. Both scales include mounting pins to secure the display assembly during transport (the pins are located on the right wheelchair ramp). To prepare the scale for transport, follow these steps:

1. Remove the display assembly from the wall by lifting up the display assembly off of the mounting screws.
2. Unplug the AC adapter from the display assembly, and remove the adapter from the outlet. Carefully store the AC adapter and cord to prevent damage during transport.
3. With the scale on the floor, fold both ramps onto the platform.
4. Position the display assembly onto the mounting pins, located on the right folded ramp. The display assembly is mounted onto the ramp by sliding the display assembly brackets onto the raised pins (see Figures 8 & 9).
5. For the 2650KL, grasp the guardrail, located on the opposite side the wheels, and lift the scale onto the two wheels. The scale can now be transported by rolling the unit on its wheels.
6. For the 2700KL, grasp the handle, located on the opposite side of the wheels, and lift the scale onto the two wheels. The scale can now be transported by rolling the unit on its wheels.

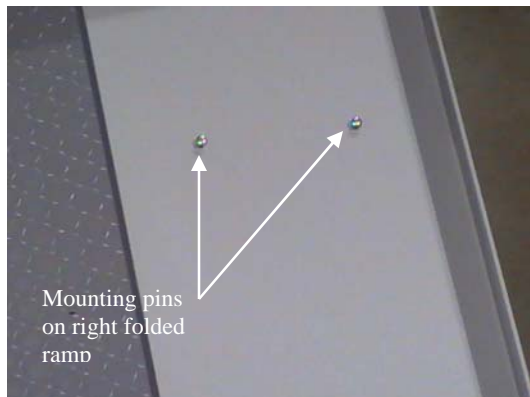

Figure 8



Figure 9

QUICK START / OPERATING INSTRUCTIONS

Keypad



Figure 10

Function	Description
ON/OFF	Turns scale on and off.
ZERO	Zeros the scale prior to a weighing.
HOLD/RELEASE ▶	Holds the weight value of the patient on the display until the button is pressed again to clear the value. Also moves the cursor from left to right on the display for entering height and pretare value.
BMI	Prompts entry of height data to calculate patient's Body Mass Index (BMI).
RECALL	Recalls the previous weight.
TARE/PRETARE	TARE-Tares out weight of an object on the platform. PRETARE-Prompts entry of a tare value that will be deducted from the weight on the platform. Also releases tare weight (returns display to zero).
UNIT/▲	Toggles between pounds and kilograms. Also used to increment height value and pretare value.
REWEIGH	Allows repeated weighing of the patient without stepping off the scale.
ENTER	Used to accept height value in BMI mode, and tare value in PRETARE mode. Also releases the recall value and BMI value.

QUICK START / OPERATING INSTRUCTIONS (CONT)

Tare Function

When using these scales, the weight of an object, such as a wheelchair, can be subtracted from the total weight in order to determine the weight of the patient alone. The Tare Function automatically performs this subtraction. The 2650KL and 2700KL scales allow tare weight to be entered manually by using the keypad, or automatically, as outlined in this section.

TARE

1. With all weight off the scale, press the **ON/OFF** button to turn on the scale.
2. Wait until the “0.0LB” or “0.0KG” appears on the display.
3. Place the wheelchair on the scale. The display will show a value for the wheelchair’s weight.
4. Press the **TARE** button. The scale will zero out, and the word “TARE” will appear at the bottom center of the display, indicating that there is a tare value for this patient’s wheelchair.
5. Remove the weight from the scale. Once it is removed from the scale, the display will show a negative weight, equal to the weight of the wheelchair.
6. Place the patient and wheelchair on the scale. The scale will automatically deduct the tare weight of the wheelchair from the gross weight of the patient and wheelchair together.
7. The weight of the patient will appear on the scale.
8. With no weight on the scale, the tare value will remain on the display until changed, cleared, or until the scale is turned off.
9. To remove the Tare, press the **TARE** button again. The word “TARE” will disappear from the bottom of the display, and the tare value will be cleared from the display. The scale will resume normal operation.

PRETARE (Limit 200.0 lb)

1. Make sure that there is no object on the weighing platform.
2. Press the **ON/OFF** button to turn on the scale.
3. Wait until the “0.0LB” or “0.0KG” and “ZERO” appear on the display.
4. Hold down the **TARE** button for 3 to 5 seconds. The word “TARE” will appear at the bottom center of the display, and the user will be prompted to enter the tare value.
5. Use the keypad **▶** and **▲** buttons to enter the weight of the wheelchair or other object. Press the **ENTER** button.
6. The value entered will show as a negative value on the display.

QUICK START / OPERATING INSTRUCTIONS (CONT)

7. Place the patient in the wheelchair and roll the wheelchair on the scale. The scale will automatically deduct the tare weight as entered, from the gross weight of the patient and the wheelchair.
8. The weight of the patient will appear on the scale.
9. With no weight on the scale, the tare value will remain on the display until changed, cleared, or until the scale is turned off.
10. To remove the Tare, press the **TARE** button again. The word "TARE" will disappear from the display and the tare value will be cleared from the display. The scale will resume normal operation.

Weighing a Patient

Note: When these scales are turned on, they will always default to the settings and units last used (lb or kg).

1. Make sure there is no object on the weighing platform.
2. Press the **ON/OFF** button to turn the scale on.
3. Wait until the "0.0LB" or "0.0KG" appears on the display.
4. Tare out the weight of the wheelchair, and roll the patient in the wheelchair onto the scale. The scale will begin to display weight information and will lock on the patient's weight when the stable weight of the patient is determined. Depending on the movement of the patient on the scale, it may take several seconds for the scale to lock onto the weight.

Caution: To prevent patient injury, the patient must be attended throughout the entire weighing event. Exercise caution when rolling patient onto and off of the scale.

5. Once a weight has been displayed, while the patient is still on the scale, Health o meter recommends performing a second weighing by pressing the **REWEIGH** button.
6. The weight may be held on the display by pressing the **HOLD/RELEASE** button. To release, press the **HOLD/RELEASE** button again.
7. After the weight measurement has been taken and is recorded, roll the patient off the scale.
8. Press the **ON/OFF** button to turn the scale off.

Weight Recall

The last weight reading on the scale can be recalled by pressing the **RECALL** button. To clear the display of the recalled weight, press the **ENTER** button.

Note: Clearing the recalled weight from the display will not clear the recalled weight from memory. The recalled weight will remain in memory until another weight is obtained.

QUICK START / OPERATING INSTRUCTIONS (CONT)

BMI Function

Body Mass Index is another name for Quetelet Index, a formula that is a convenient indicator of BMI with various exemptions, such as athletes, children, the elderly, and the infirm.

Note: The scale will not calculate BMI for a patient that is 24 pounds (12 kg) or less. If a height is not entered for the patient within 30 seconds of pressing the **BMI** button, the scale will return to the normal weighing mode.

1. Make sure there is no object on the weighing platform.
2. Press the **ON/OFF** button to turn the scale on.
3. Wait until the "0.0" LB or "0.0" KG appears on the display.
- 4 Ask the patient to step on the scale. The scale will begin to display weight information and will lock on the patient's weight when the stable weight of the patient is determined. Depending on the movement of the patient on the scale, it may take several seconds for the scale to lock onto the weight.
5. Once a weight has been displayed, while the patient is still on the scale, Health o meter recommends performing a second weighing by pressing the **REWEIGH** button.
6. After obtaining the patient's weight on the scale, press the **BMI** button while the scale is on.
7. The scale will prompt you to enter the patient's height. Use the keypad **▲** and **▶** buttons to enter the patient's height.

Note: When weighing in pounds, the height is displayed in inches. When weighing in kilograms, the height is displayed in centimeter.

8. Once height is keyed in, press the **ENTER** button.
9. The display will show the patient's BMI.
10. Press the **ENTER** button to return to the normal weighing mode of the scale.

MAINTENANCE

Maintenance

The following pages provide instructions for maintenance, cleaning, calibrating, and troubleshooting for the 2650KL or 2700KL scale. Maintenance operations other than those described in this manual should be performed by qualified service personnel.

Caution: Before first use, or after long periods of non-use, check the scale for proper operation and function. If the scale does not operate correctly, refer to qualified service personnel.

1. Check overall appearance of the total scale for any obvious damage, wear, and tear.
2. Inspect the AC adapter for cord cracking or fraying, or for broken/bent prongs.

Cleaning

Proper care and cleaning is essential to ensure a long life of accurate and effective operation.

Caution: Disconnect the scale from the AC adapter power source prior to cleaning the unit.

1. Clean all external surfaces with a clean damp cloth or tissue. Mild antimicrobial or antibacterial soap and water solution may be used. Dry with a clean soft cloth.
2. Do not immerse the scale into cleaning or other liquid solutions.
3. Do not use Isopropyl Alcohol or other solutions to clean the display surface.
4. Do not use abrasive cleaners.

CALIBRATION

Calibration

These scales have been factory calibrated, and does not require calibration prior to use. For maintenance, the scale can be calibrated. Calibration of your 2650KL or 2700KL scale is performed using kilograms (kg) or pounds (lb), according to the units of measure used upon entering into the calibration path. The following calibration assumes the scale is set to pounds, and 400 lb (the default weight) is employed as the calibration weight.

Scale Calibration

Operator Action	Display
1. Make sure the display is turned off, then press and hold the HOLD/RELEASE button while pressing the ON/OFF button.	"U 01" followed by a 5 digit 'idle scale count' number.
2. Press the ENTER button.	"CAL".
3. Make sure there is nothing on the scale, then press the ENTER button again.	"Clear" followed by "0400.0LB".
4. Use the ► and ▲ buttons to set the calibration weight to a value other than the default weight. The calibration weight should be as high as possible, with 400 lb as a minimum calibration weight.	Shows "400.0" or entered calibration weight.
5. Press the ENTER button.	Alternating "Load" followed by "400.0LB".
6. Load the scale with the required weight.	Display increments showing raw weight data.
7. Without touching or shaking the scale, allow the display to stabilize, then press the ENTER button.	"SUCC" or "Err1".
8. If the calibration is successful, the display will show SUCC and turn off. If the calibration is not successful, the display will show Err1 and turn off. Contact customer service for an Err1 display (1-800-638-3722).	-----

TROUBLESHOOTING

Troubleshooting

Before contacting service personnel, refer to the following instructions to check and to correct any failures.

Symptom	Possible Cause	Corrective Action
Scale does not turn on	<ol style="list-style-type: none"> 1. Dead Battery 2. Faulty electrical outlet 3. Bad power supply 	<ol style="list-style-type: none"> 1. Replace batteries 2. Use a different outlet 3. Replace AC adapter
Questionable weight or the scale does not zero	<ol style="list-style-type: none"> 1. External object interfering with the scale 2. The display did not show "0.0" before weighing 3. Scale is not placed on a level floor 4. Scale is out of calibration 5. Improper Tare 	<ol style="list-style-type: none"> 1. Remove interfering object from the scale 2. Ask the patient to get off the scale, zero the scale and begin weighing process again 3. Place the scale on a level floor and begin weighing process again 4. Check weight with known weight value 5. Place the item to be tared on the scale. Press REWEIGH. Once the weight of the item is displayed, press TARE. Place the patient and the tared item back on the scale. Press REWEIGH again
Weighing is performed but the weighing process takes too long and the weight does not lock on the displayed	The patient is not sitting or standing still	Ask the patient to stand or sit still
The display shows "Over" message	The load on the scale exceeds the capacity (1000 lb / 454 kg)	Remove the excess weight and use the scale according to its limits
The display shows "Lo bAtt" message	The batteries are discharged	Replace batteries according to instructions

WARRANTY

Limited Warranty

What does the Warranty Cover?

Health o meter® Professional scales are warranted from date of purchase against defects of materials or in workmanship for a period of two (2) years. If product fails to function properly, return the product, freight prepaid and properly packed to Pelstar, LLC (see "To Get Warranty Service", below, for instructions). If the manufacturer determines that a defect of material or in workmanship exists, the customer's sole remedy will be repair or replacement of the scale at no charge. Replacement will be made with a new or remanufactured product or component. If the product is no longer available, replacement may be made with a similar product of equal or greater value. All parts including repaired and replaced parts are covered only for the original warranty period.

Who is Covered?

The original purchaser of the product must have proof of purchase to receive warranty service. Please save your invoice or receipt. Pelstar dealers or retail stores selling Pelstar products do not have the right to alter, or modify or any way change the terms and conditions of this warranty.

What is Excluded?

Your warranty does not cover normal wear of parts or damage resulting from any of the following: negligent use or misuse of the product, use on improper voltage or current, use contrary to the operating instructions, abuse including tampering, damage in transit, or unauthorized repair or alternations. Further, the warranty does not cover natural disasters, such as fire, flood, hurricanes and tornadoes. This warranty gives you specific legal rights, and you may also have other rights that vary from country to country, state to state, province to province or jurisdiction to jurisdiction.

To get Warranty Service make sure you keep your sales receipt or document showing proof of purchase. Call (+1) 800-638-3722 or (+1) 708-377-0600 to receive a return authorization (RA) number, which must be included on the return label. Attach your proof of purchase to your defective product along with your name, address, daytime telephone number and description of the problem. Carefully package the product and send with shipping and insurance prepaid to:

Pelstar, LLC
Attention R/A# _____
Return Department
9500 West 55th Street
McCook, IL 60525

If your scale is not covered by warranty, or has been damaged, an estimate of repair costs or replacement costs will be provided to you for approval, prior to servicing or replacing.



PELSTAR, LLC

9500 West 55th Street • McCook, IL 60525 • USA

1-800-638-3722 or 1-708-377-0600

PLEASE REGISTER YOUR SCALE FOR WARRANTY COVERAGE AT:
<http://www.homscales.com/customers/registration.aspx>

Health o meter® is a registered trademark of Sunbeam Products, Inc. used under license.

Health o meter® Professional products are manufactured, designed, and owned by Pelstar, LLC.

We reserve the right to improve, enhance, or modify Health o meter® Professional product features or specifications without notice.

© Pelstar, LLC 2013



P/N UM2650KL / 2700KL Rev 2-031913